

特徴 Features

当社測定用ICソケットの開発で蓄積されたノウハウから誕生した、QFP試作用ICソケットICと同一フットパターンのため、量産基板をそのまま試作用基板として使用可能
位置決めピンの有無を選択可能
エミュレータ用専用プローブ (ICP) もラインナップ
RoHS指令対応

QFP-test socket developed using Yamaichi Electronics expertise in Test & Burn-in IC socket production

Lead-foot-patterned solder terminal enabling direct use of production PCB for QFP test process
Products equipped with positioning pins available
Various emulation-probes (ICP) available
RoHS compliant

品名表示方法 Ordering Code

IC149 - 100 - 0 25 - B 51

① ② ③ ④ ⑤

①	IC149シリーズ IC149 Series
②	芯数 Number of contacts
③	位置決めピン 1: 有 0: 無 Positioning pins - 1: With 0: Without
④	芯数別設計順位 Design number
⑤	コンタクトめっき仕様 B: 金 Plating of contact - B: Gold

仕様 Specifications

性能 Performance

接触抵抗 30mΩ以下 10mAにて
Contact Resistance 30mΩ max. @ 10mA

使用温度 -25°C~+85°C
Operating Temperature -25°C to +85°C

はんだ付け温度 220°C以下VPS 1分間以内
Soldering Temperature VPS, 220°C max., 1 minute or less

材質 Materials

インシュレータ PPS、PA樹脂ガラス入り (UL94V-0)
Insulator PPS and PA glass-filled, UL94V-0

コンタクト 銅合金、金めっき
Contact Copper Alloy, Gold plating

製品ラインナップ Series Lineup

品名 Part Number	PKG PKG	芯数 No. of Contacts	ピッチ Pitch	固定金具の有無 with or without fixing metals	ICP*1 品名 Applicable ICP note.1
IC149-044-*49-B5*	QFP	44	0.80	B5:有 / B51:無 B5:With / B51:Without	ICP-044-2
IC149-064-*01-B5	QFP	64	1.00	無 Without	—
IC149-064-*08-B5	QFP	64	0.80	無 Without	ICP-064-2
IC149-080-*12-B5	QFP	80	0.80	無 Without	ICP-080-3
IC149-080-*17-B5	QFP	80	0.65	無 Without	ICP-080-4
IC149-080-*21-B5	QFP	80	0.80	無 Without	ICP-080-5
IC149-080-*30-B5*	QFP	80	0.50	B5:有 / B51:無 B5:With / B51:Without	ICP-080-6
IC149-080-*31-B5*	QFP	80	0.50	B5:有 / B51:無 B5:With / B51:Without	ICP-080-6
IC149-080-*51-B5*	QFP	80	0.65	B5:有 / B51:無 B5:With / B51:Without	ICP-080-7
IC149-080-*58-B5*	QFP	80	0.50	B5:有 / B51:無 B5:With / B51:Without	ICP-080-6
IC149-100-*05-B5	QFP	100	0.65	無 Without	※2
IC149-100-*14-B5	QFP	100	0.65	無 Without	ICP-100-4
IC149-100-*25-B5*	QFP	100	0.50	B5:有 / B51:無 B5:With / B51:Without	ICP-100-5
IC149-100-*28-B5	BQFP	100	0.635	無 Without	ICP-100-6
IC149-100-*54-B5*	QFP	100	0.50	B5:有 / B51:無 B5:With / B51:Without	ICP-100-5
IC149-112-*42-B5	QFP	112	0.65	無 Without	ICP-112-2
IC149-120-*43-B5*	QFP	120	0.40	B5:有 / B51:無 B5:With / B51:Without	ICP-120-2
IC149-132-*15-B5	QFP	132	0.635	無 Without	—
IC149-144-*45-B5*	QFP	144	0.50	B5:有 / B51:無 B5:With / B51:Without	ICP-144-1
IC149-160-*23-B5	QFP	160	0.65	有 With	ICP-160-1
IC149-160-*50-B5*	QFP	160	0.50	B5:有 / B51:無 B5:With / B51:Without	—
IC149-176-*66-B5*	QFP	176	0.50	B5:有 / B51:無 B5:With / B51:Without	—
IC149-208-*61-B5*	QFP	208	0.50	B5:有 / B51:無 B5:With / B51:Without	—
IC149-240-*67-B5*	QFP	240	0.50	B5:有 / B51:無 B5:With / B51:Without	—

※1 エミュレータ用プローブ (詳細につきましてはお問合せください)

※2 ICPを取り付ける場合は、同寸法で取り付け加工を施した IC149-KS-11113-*をご使用ください。

IC149-KS-11113-*

品名末尾の"*"は位置決めピンの有無を表します。(0: 位置決めピン無、1: 位置決めピン有)
ICPはICP-100-4となります。

note.1 ICP: Emulator probe (Please contact us for the details.)

note.2 IC149-100-*05-B5 can not be used with ICP-100-4.

Please choose IC149-KS-11113-* instead.

The mark "*" indicates whether positioning pin is equipped with or without. (0: Without / 1: With)

適合IC寸法 Applicable IC Dimensions

寸法図 Dimension drawing

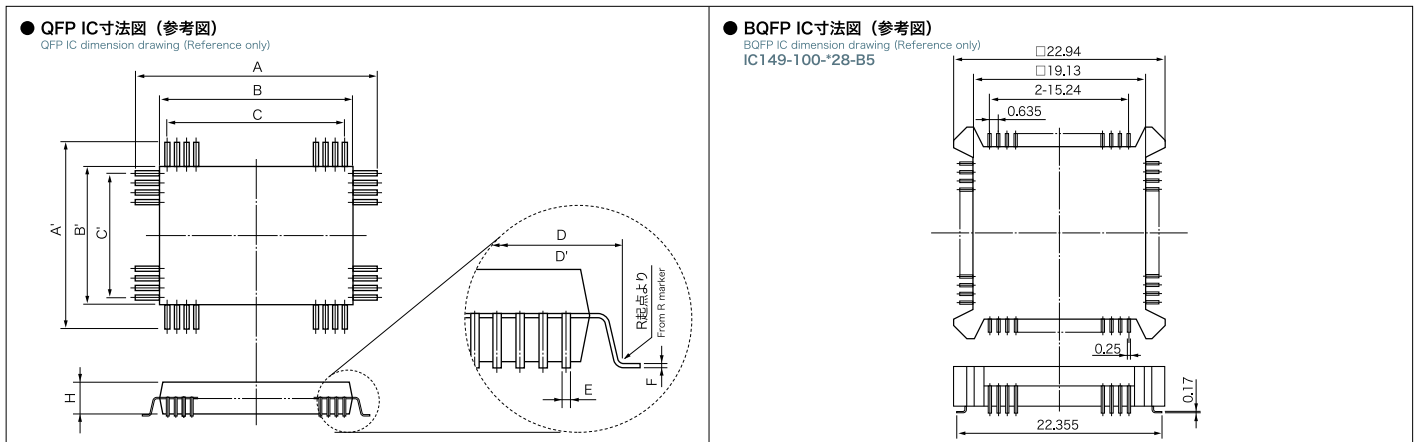

寸法表 Table of dimensions 寸法単位：mm (Unit: mm)

品名 Part Number	芯数 No. of Contacts	ピッチ Pitch	A	A'	B	B'	C	C'	D	D'	E	F	H
IC149-044-*49-B5*	44	0.80	17.20	17.20	14.00	14.00	8.00	8.00	15.60	15.60	0.35	0.15	3.05 MAX.
IC149-064-*01-B5	64	1.00	23.60~ 26.10	17.60~ 20.10	20.00	14.00	18.00	12.00	22.90 MAX.	17.00 MAX.	0.35	0.15	3.05 MAX.
IC149-064-*08-B5	64	0.80	17.20	17.20	14.00	14.00	12.00	12.00	15.60 MAX.	15.60 MAX.	0.35	0.15	2.15
IC149-064-*08-B5 (セラミックパッケージ)													4.85 MAX.
IC149-080-*12-B5	80	0.80	24.80	18.80	20.00	14.00	18.40	12.00	22.90 MAX.	17.00 MAX.	0.35	0.15	3.05 MAX.
IC149-080-*17-B5	80	0.65	17.20	17.20	14.00	14.00	12.35	12.35	15.60	15.60	0.30	0.15	3.00
IC149-080-*21-B5	80	0.80	23.20	17.20	20.00	14.00	18.40	12.00	21.90	15.90	0.30	0.15	2.70
IC149-080-*21-B5 (セラミックパッケージ)					13.20				21.40	15.40	0.30	0.15	
IC149-080-*30-B5*	80	0.50	14.00	14.00	12.00	12.00	9.50	9.50	13.00	13.00	0.20	0.15	2.80 MAX.
IC149-080-*30-B5* (セラミックパッケージ)										12.00			2.80
IC149-080-*31-B5*	80	0.50	13.60	13.60	12.00	12.00	9.50	9.50	12.60	12.60	0.22	0.17	1.20 MAX.
IC149-080-*51-B5*	80	0.65	16.00	16.00	14.00	14.00	12.35	12.35	15.00	15.00	0.30	0.17	1.40
IC149-080-*58-B5*	80	0.50	14.00	14.00	12.00	12.00	9.50	9.50	13.00	13.00	0.20	0.15	2.80 MAX.
IC149-100-*05-B5	100	0.65	23.60~ 26.10	17.60~ 20.10	20.00	14.00	18.85	12.35	22.90	17.00	0.30	0.15	2.90 MAX.
IC149-100-*14-B5	100	0.65	23.20	17.20	20.00	14.00	18.85	12.35	21.80	15.80	0.30	0.15	3.50 MAX.
IC149-100-*25-B5*	100	0.50	16.00	16.00	14.00	14.00	12.00	12.00	15.00	15.00	0.20	0.15	2.90 MAX.
IC149-100-*28-B5	この製品に関しましては、上記BQFP IC寸法図を参照下さい。												
IC149-100-*54-B5*	100	0.50	16.00	16.00	14.00	14.00	12.00	12.00	15.00	15.00	0.20	0.15	2.90 MAX.
IC149-112-*42-B5	112	0.65	23.20	23.20	20.00	20.00	17.55	17.55	21.60	21.60	0.30	0.15	3.05 MAX.
IC149-120-*43-B5*	120	0.40	16.00	16.00	14.00	14.00	11.60	11.60	15.00	15.00	0.15	0.17	2.90 MAX.
IC149-132-*15-B5	132	0.635	27.43	27.43	22.36	22.36	20.32	20.32	26.16	26.16	0.25	0.16	4.00 MIN.
IC149-144-*45-B5*	144	0.50	22.00	22.00	20.00	20.00	17.50	17.50	21.00	21.00	0.20	0.15	1.70 MAX.
IC149-160-*23-B5	160	0.65	32.00	32.00	28.00	28.00	25.35	25.65	30.40	30.40	0.30	0.15	4.00 MAX.
IC149-160-*50-B5*	160	0.50	26.00	26.00	24.00	24.00	19.50	19.50	24.80	24.80	0.22	0.14	2.00 MAX.
IC149-176-*66-B5*	176	0.50	26.00	26.00	24.00	24.00	21.50	21.50	24.80	24.80	0.22	0.17	1.80 MAX.
IC149-208-*61-B5*	208	0.50	30.60	30.60	28.00	28.00	25.50	25.50	29.60	29.60	0.22	0.15	4.07 MAX.
IC149-240-*67-B5*	240	0.50	34.60	34.60	32.00	32.00	29.50	29.50	33.40	33.40	0.22	0.17	4.10 MAX.

寸法図 Dimension drawing

● IC149-044-＊49-B5＊

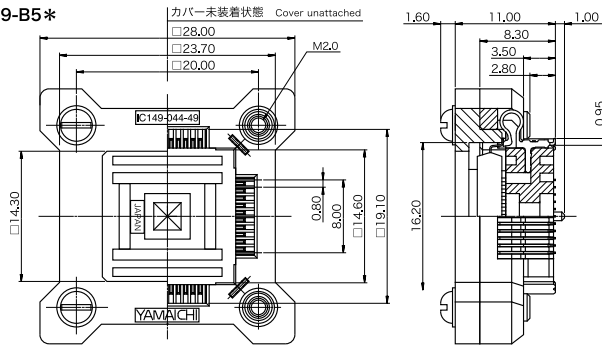

● プリント板レイアウト (参考図)

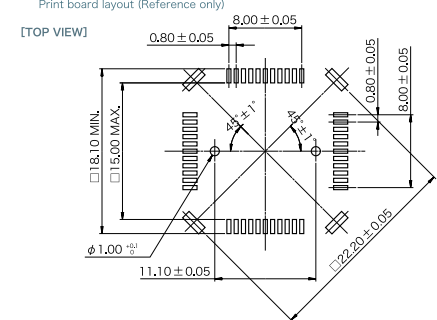

● IC149-064-＊01-B5

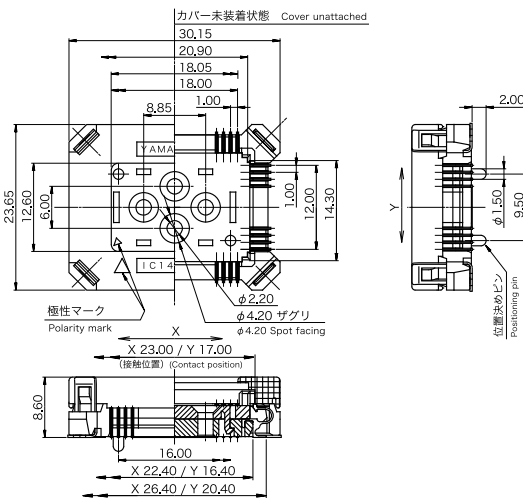

● プリント板レイアウト (参考図)

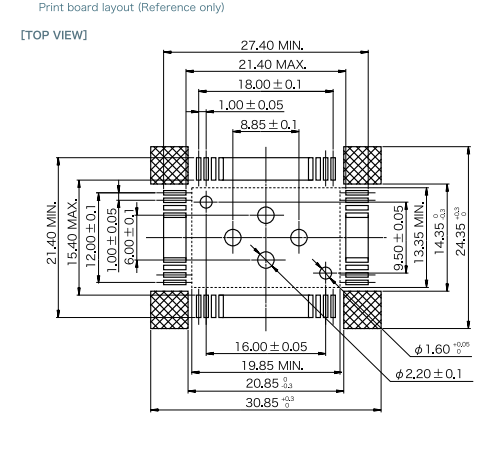

● IC149-064-＊08-B5

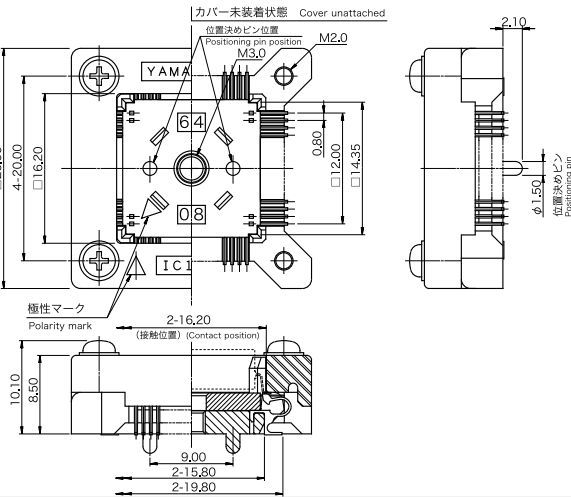

● プリント板レイアウト (参考図)

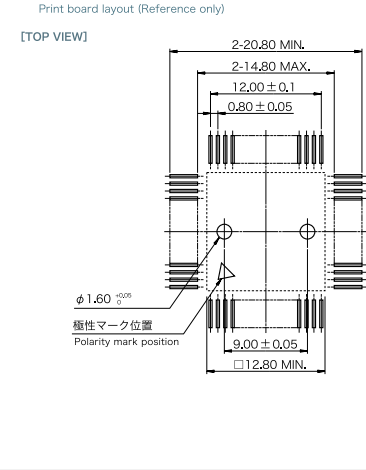

● IC149-080-＊12-B5

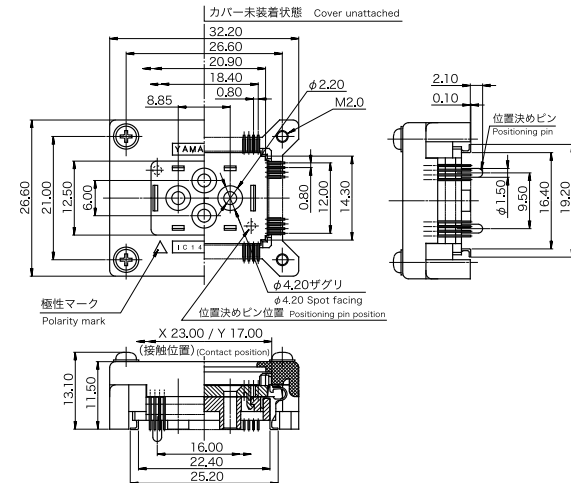

● プリント板レイアウト (参考図)

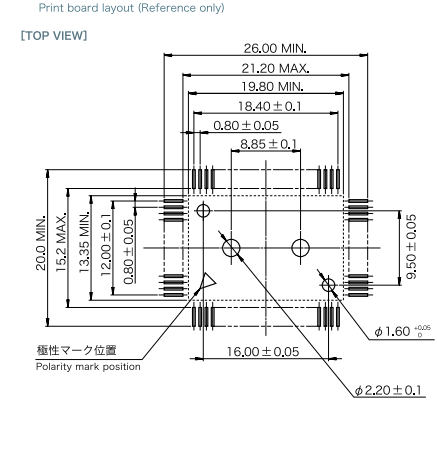

寸法図 Dimension drawing

● IC149-080-※17-B5

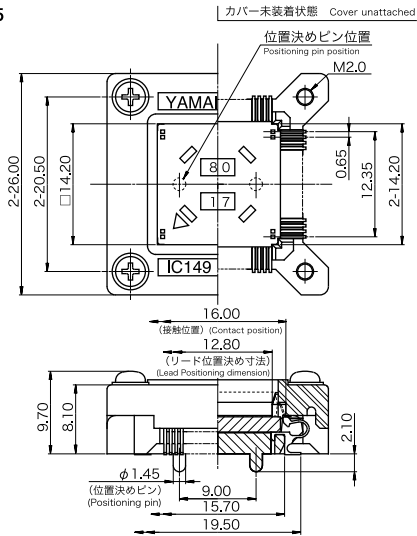

● プリント板レイアウト (参考図)

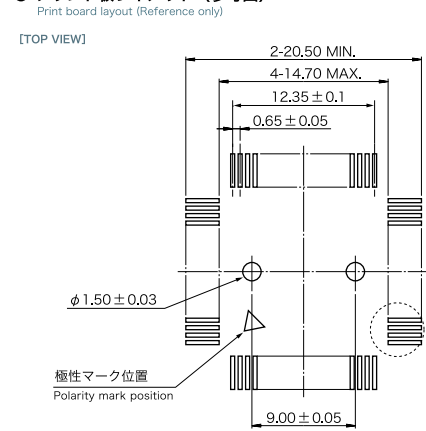

● IC149-080-※21-B5

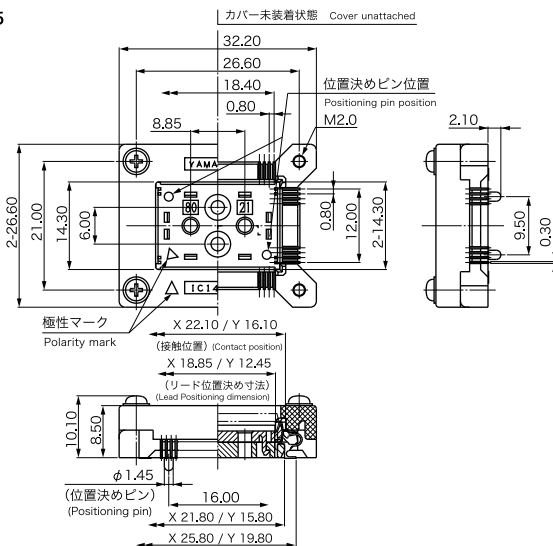

● プリント板レイアウト (参考図)

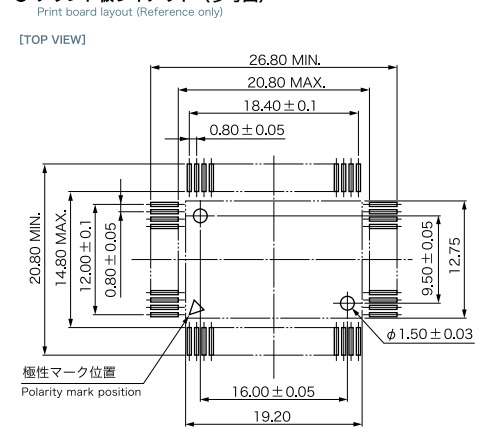

● IC149-080-※30-B5*

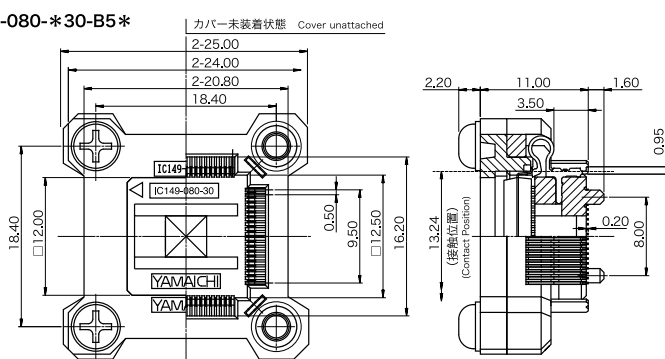

● プリント板レイアウト (参考図)

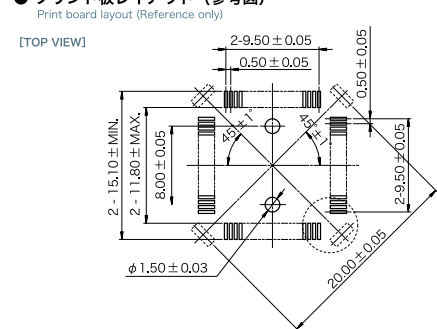

● IC149-080-※31-B5*

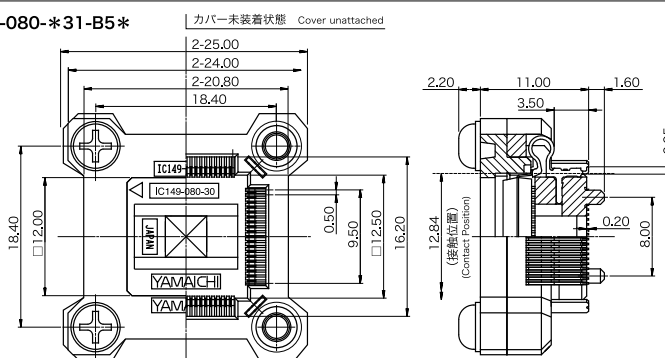

● プリント板レイアウト (参考図)

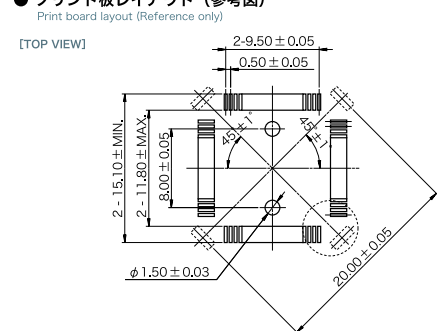

寸法図 Dimension drawing

● IC149-100-※14-B5

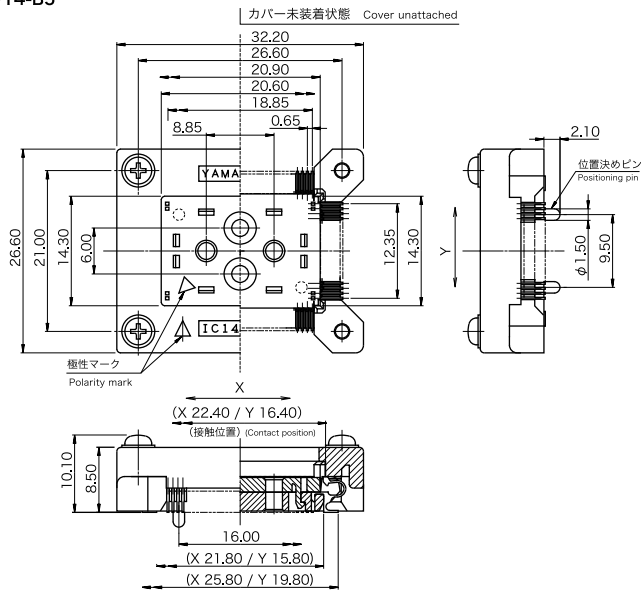

● プリント板レイアウト (参考図)

Print board layout (Reference only)

[TOP VIEW]

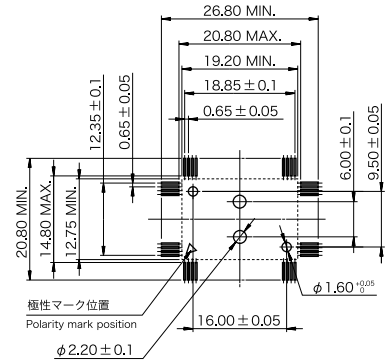

● IC149-100-※25-B5*

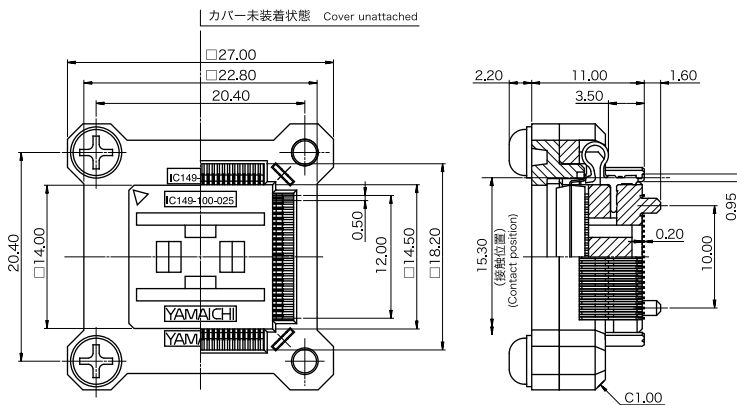

● プリント板レイアウト (参考図)

Print board layout (Reference only)

[TOP VIEW]

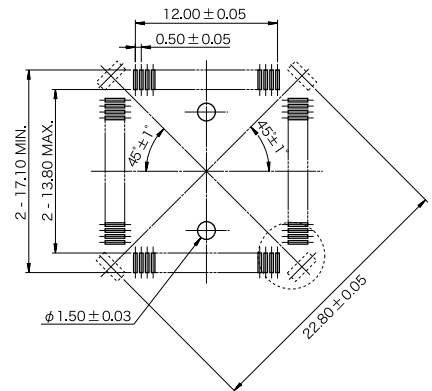

● IC149-100-※28-B5

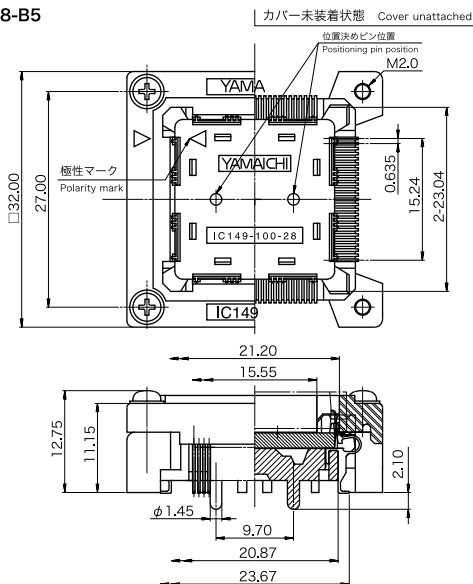

● プリント板レイアウト (参考図)

Print board layout (Reference only)

[TOP VIEW]

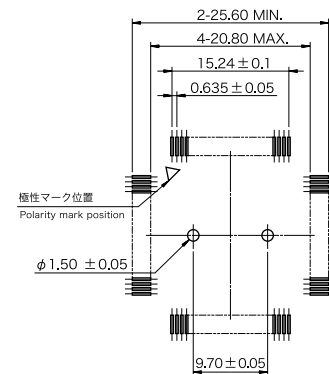

寸法図 Dimension drawing

● IC149-100*54-B5*

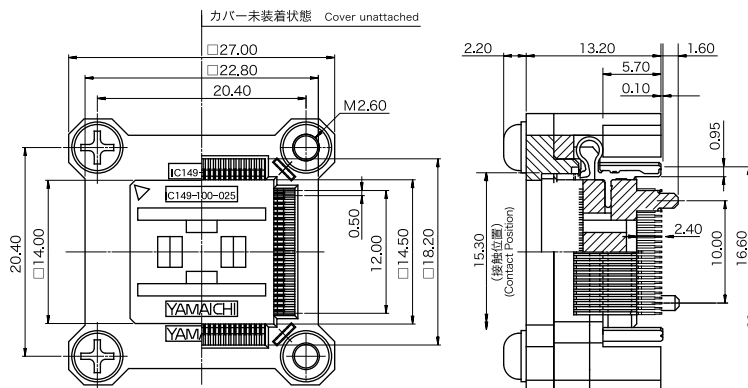

● プリント板レイアウト (参考図)

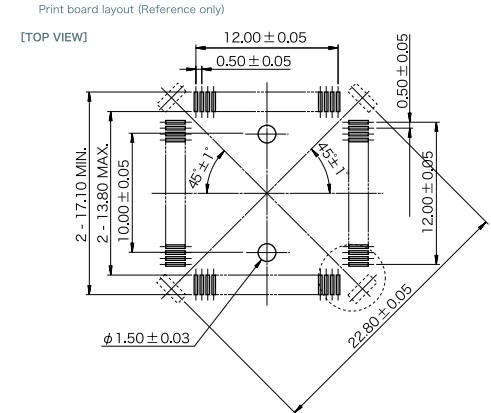

● IC149-112*42-B5

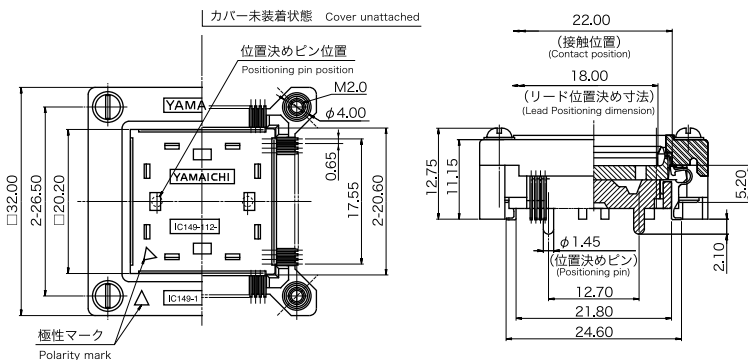

● プリント板レイアウト (参考図)

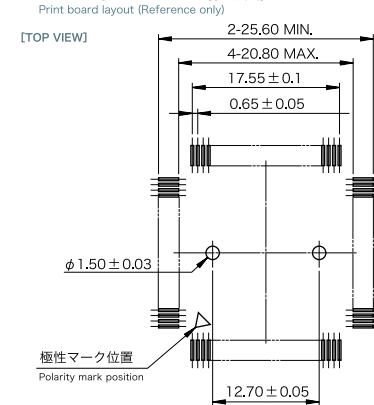

● IC149-120*43-B5*

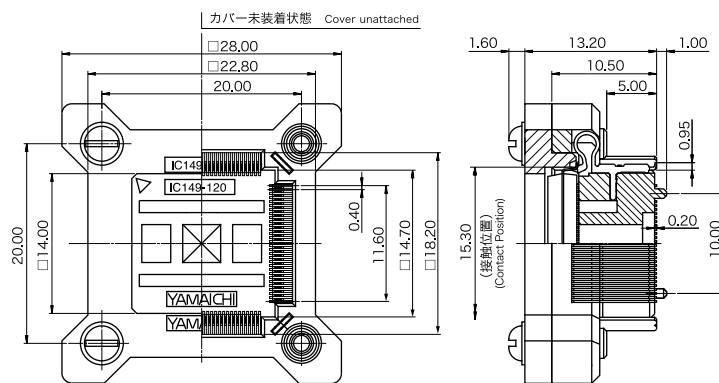

● プリント板レイアウト (参考図)

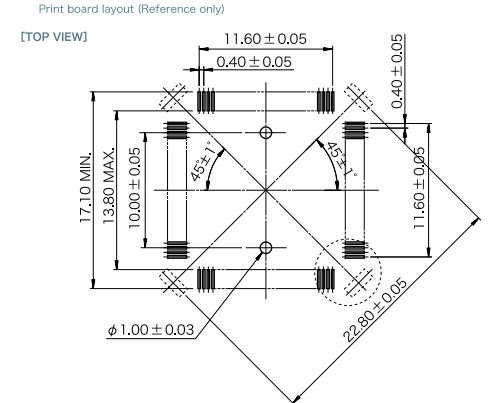

● IC149-132*15-B5

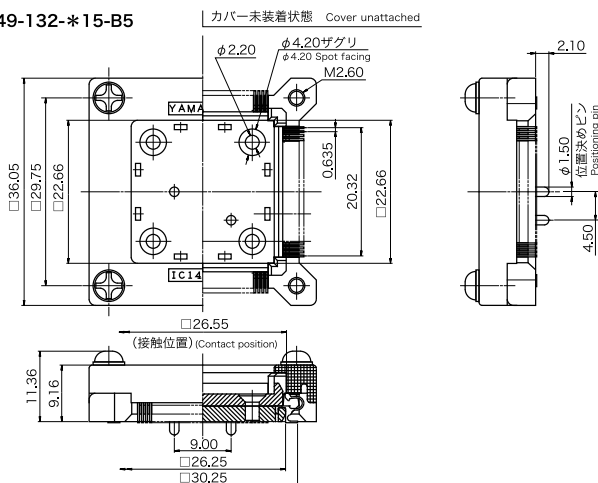

● プリント板レイアウト (参考図)

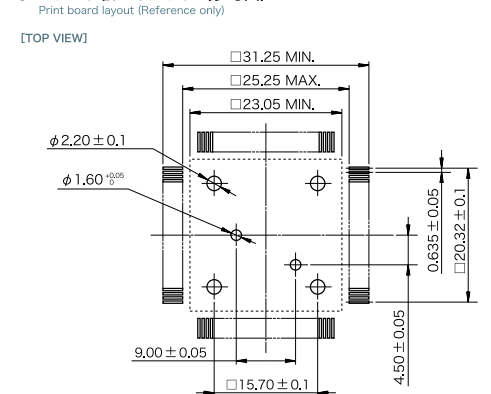

寸法図 Dimension drawing

● IC149-144-＊45-B5＊

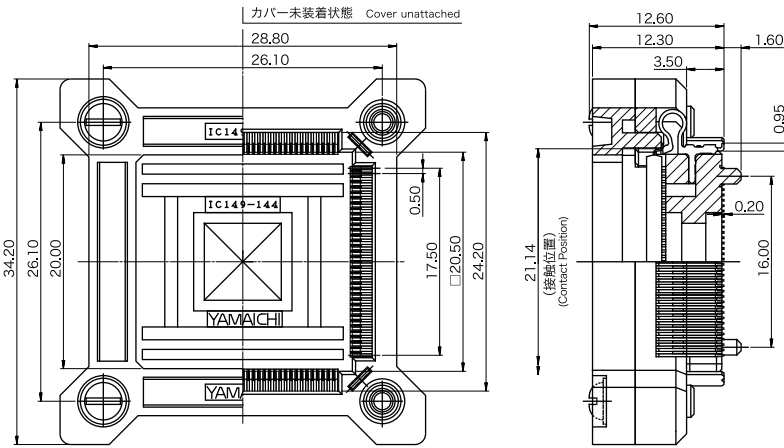

● プリント板レイアウト (参考図)

Print board layout (Reference only)

[TOP VIEW]

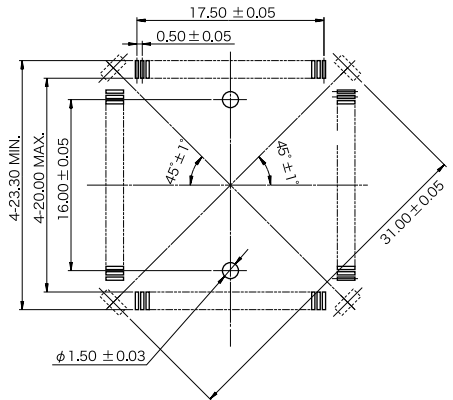

● IC149-160-＊23-B5

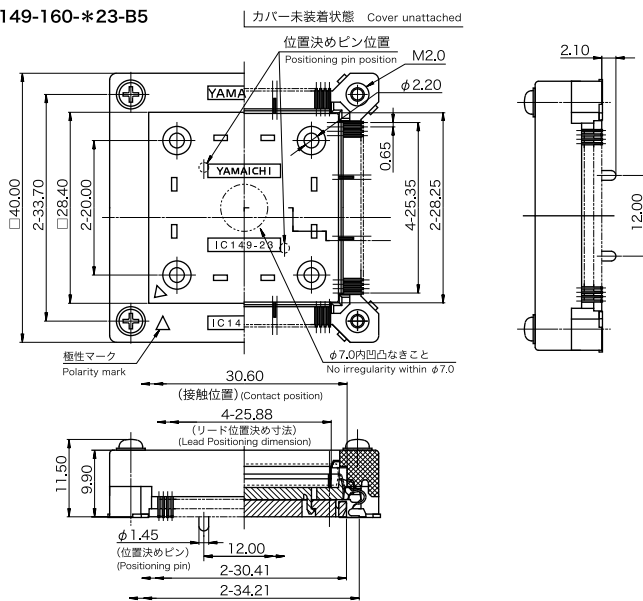

● プリント板レイアウト (参考図)

Print board layout (Reference only)

[TOP VIEW]

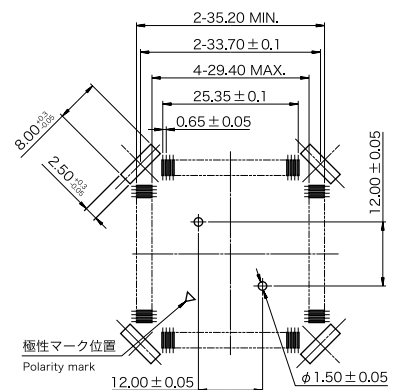

● IC149-160-＊50-B5＊

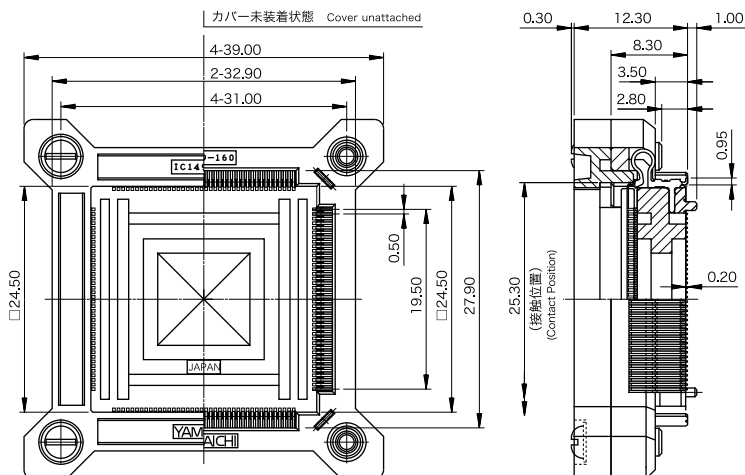

● プリント板レイアウト (参考図)

Print board layout (Reference only)

[TOP VIEW]

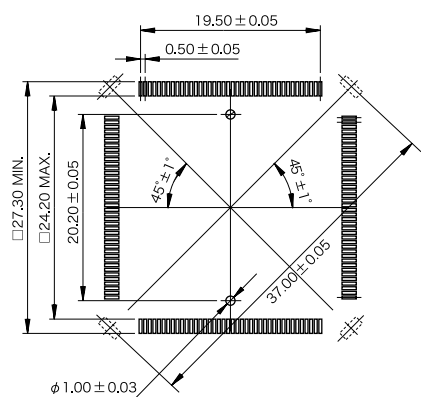

寸法図 Dimension drawing

● IC149-176-*66-B5*

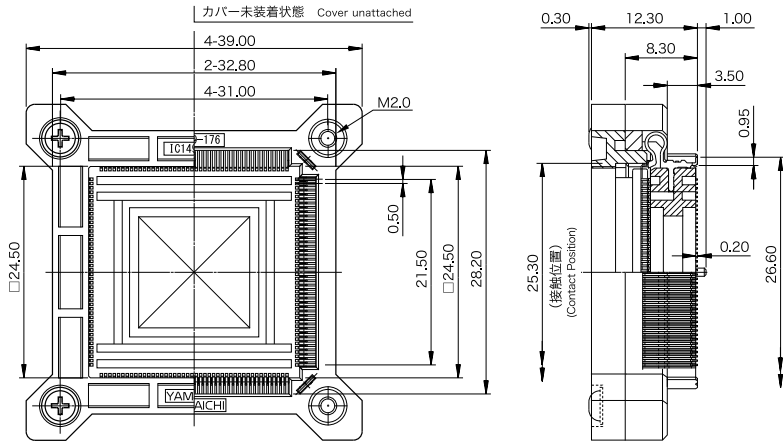

● プリント板レイアウト (参考図)

Print board layout (Reference only)

[TOP VIEW]

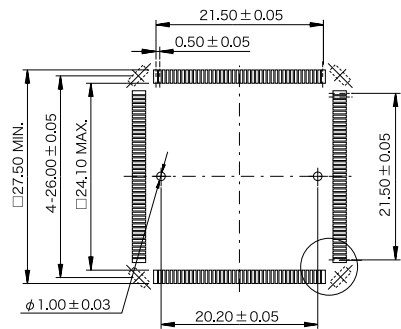

● IC149-208-*61-B5*

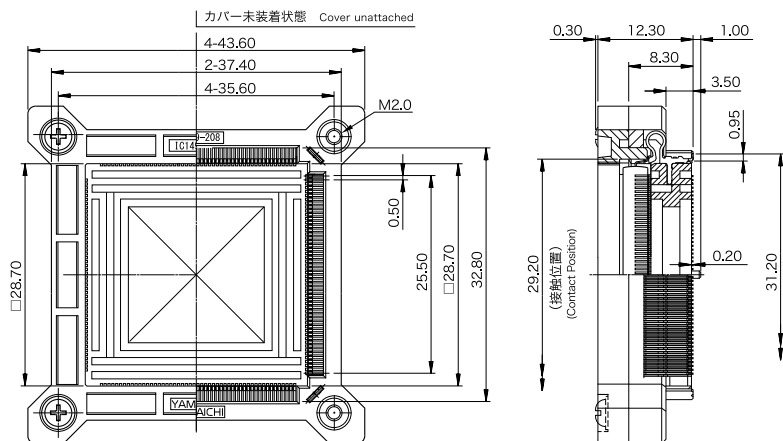

● プリント板レイアウト (参考図)

Print board layout (Reference only)

[TOP VIEW]

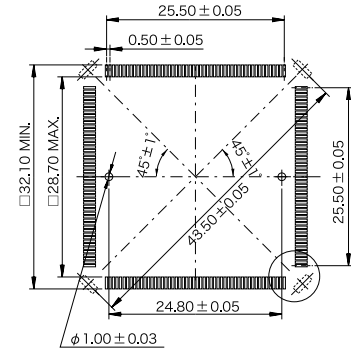

● IC149-240-*67-B5*

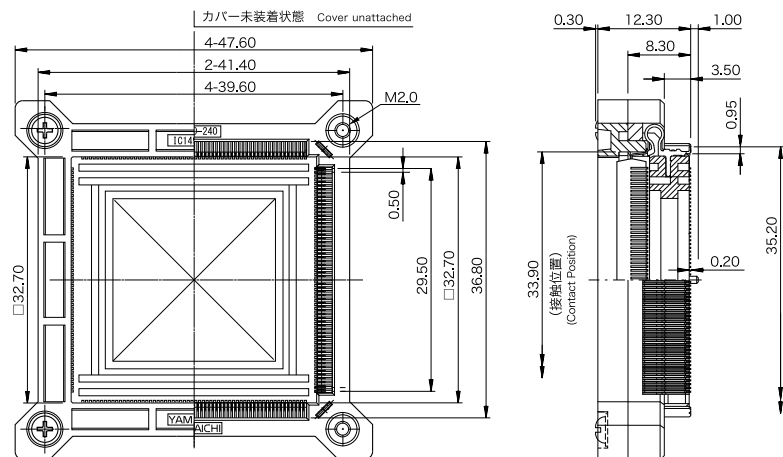

● プリント板レイアウト (参考図)

Print board layout (Reference only)

[TOP VIEW]

